

GBIC-MMF

**1-P 1000Base-SX Mini-GBIC module (MM, LC)
550m/850nm, 1.25Gbps, 3.3/5v**



Features

- Compliant with Fiber Channel 100-M5-SN-I and 100-M6-SN-I standard
- Compliant with IEEE802.3z Gigabit Ethernet standard
- Industry standard small form pluggable (SFP) package
- Duplex LC connector
- Differential LVPECL inputs and outputs
- Single power supply 3.3V
- TTL signal detect indicator
- Hot Pluggable
- Class 1 laser product complies with EN 60825-1

Application

- Distributed multi-processing
- Switch to switch interface
- High speed I/O for file server
- Bus extension application
- Channel extender, data storage

Absolute Maximum Ratings

PARAMETER	SYMBOL	MIN	MAX	UNITS	NOTE
Storage Temperature	T_S	-40	85	°C	
Supply Voltage	V_{CC}	-0.5	6.0	V	
Input Voltage	V_{IN}	-0.5	V_{CC}	V	
Output Current	I_o	---	50	mA	
Operating Current	I_{OP}	---	400	mA	

GBIC-MMF

**1-P 1000Base-SX Mini-GBIC module (MM, LC)
550m/850nm, 1.25Gbps, 3.3/5v**

Recommended Operating Conditions

PARAMETER	SYMBOL	MIN	MAX	UNITS	NOTE
Ambient Operating Temperature	T_{AMB}	0	70	°C	
Supply Voltage	V_{CC}	3.1	3.5	V	
Supply Current	$I_{TX} + I_{RX}$	---	300	mA	

Transmitter Electro-optical Characteristics

$V_{CC} = 3.1\text{ V to }3.5\text{ V}, T_A = 0\text{ °C to }70\text{ °C}$

PARAMETER	SYMBOL	MIN	TYP.	MAX	UNITS	NOTE
Output Optical Power (50/125 μm fiber, NA=0.20) (62.5/125 μm fiber, NA=0.275)	P_{out}	-9.5	---	-4	dBm	
Extinction Ratio	ER	9	---	---	dB	
Coupled Power Ratio	CPR	9	---	---	dB	
Center Wavelength	λ_C	830	850	860	nm	
Spectral Width (RMS)	$\Delta\lambda$	---	---	0.85	nm	
Rise/Fall Time, (20–80%)	$T_{r,f}$	---	---	260	ps	
Relative Intensity Noise	RIN	---	---	-117	dB/Hz	
Total Jitter	TJ	---	---	227	ps	
Output Eye	Compliant with IEEE802.3z					
Max. P_{out} TX-DISABLE Asserted	P_{OFF}	---	---	-35	dBm	
Differential Input Voltage	V_{DIFF}	0.65	---	2.0	V	
Transmit Fault Output-Low	TX_FAULT_L	0.0	---	0.5	V	
Transmit Fault Output-High	TX_FAULT_H	2.4	---	V_{CC}	V	
TX_DISABLE Assert Time	t_{off}	---	---	10	μs	
TX_DISABLE Negate Time	t_{on}	---	---	1	ms	
Time to initialize, include reset of TX_FAULT	t_{init}	---	---	300	ms	
TX_FAULT from fault to assertion	t_{fault}	---	---	100	μs	
TX_DISABLE time to start reset	t_{reset}	10	---	---	μs	

GBIC-MMF

**1-P 1000Base-SX Mini-GBIC module (MM, LC)
550m/850nm, 1.25Gbps, 3.3/5v**

Receiver Electro-optical Characteristics

$V_{CC} = 3.1\text{ V to }3.5\text{ V}, T_A = 0\text{ }^{\circ}\text{C to }70\text{ }^{\circ}\text{C}$

PARAMETER	SYMBOL	MIN	TYP.	MAX	UNITS	NOTE
Optical Input Power-maximum	P_{IN}	0	---	---	dBm	BER < 10^{-12}
Optical Input Power-minimum (Sensitivity)	P_{IN}	---	---	-18	dBm	BER < 10^{-12}
Operating Center Wavelength	λ_C	770	---	860	nm	
Optical Return Loss	ORL	12	---	---	dB	
Receiver Electrical 3dB Upper Cutoff Frequency	---	---	---	1500	MHz	
Loss of Signal-Asserted	P_A	---	---	-18	dBm	
Loss of Signal-Deasserted	P_D	-31	---	---	dBm	
Differential Output Voltage	V_{DIFF}	0.37	---	2.0	V	
Data Output Rise, Fall Time (20–80%)	$T_{r,f}$	---	---	0.35	ns	
Receiver Loss of Signal Output Voltage-Low	RX_LOS_L	0	---	0.5	V	
Receiver Loss of Signal Output Voltage-High	RX_LOS_H	2.4	---	V_{CC}	V	
Receiver Loss of Signal Assert Time (off to on)	t_{A,RX_LOS}	---	---	100	μs	
Receiver Loss of Signal Assert Time (on to off)	t_{D,RX_LOS}	---	---	100	μs	

GBIC-MMF

**1-P 1000Base-SX Mini-GBIC module (MM, LC)
550m/850nm, 1.25Gbps, 3.3/5v**

Block Diagram of Transceiver

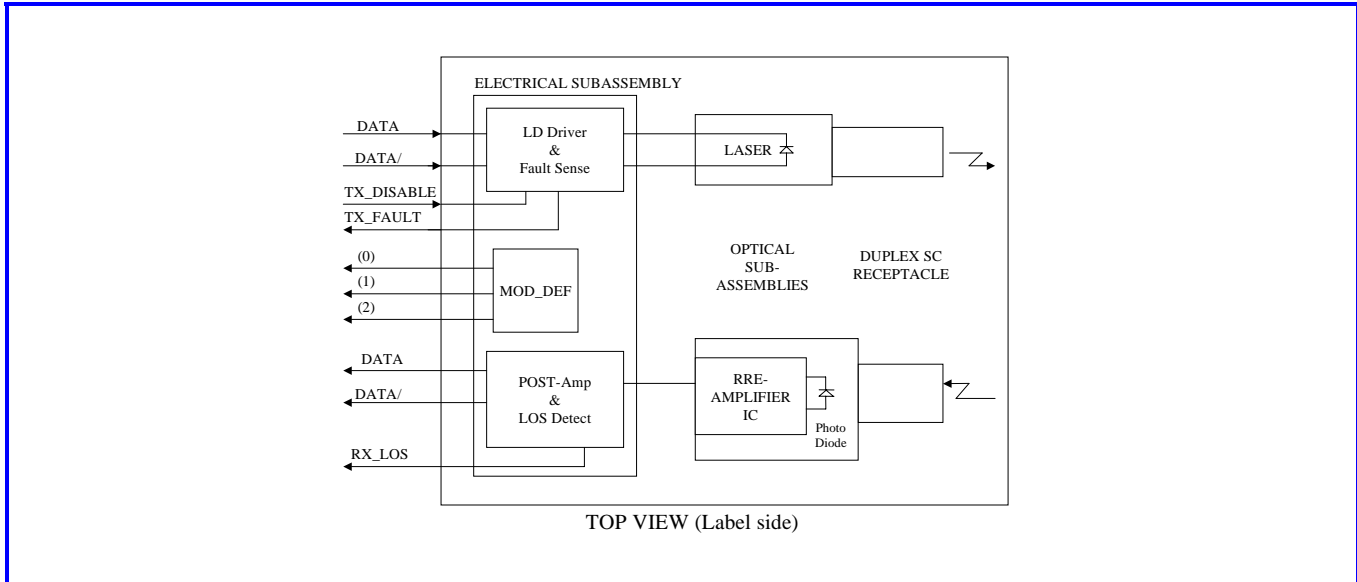

Transmitter Section

The transmitter section consists of a 850 nm VCSEL in an eye safe optical subassembly (OSA) which mates to the fiber cable. The laser OSA is driven by a LD driver IC which converts differential input LVPECL logic signals into an analog laser driving current.

TX_FAULT

When sensing an improper power level in the laser driver, the SFP set this signal high and turns off the Laser. TX_FAULT can be reset with the TX_DISABLE line. The signal is in TTL level.

TX_DISABLE

The TX_DISABLE signal is high (TTL logic “1”) to turn off the laser output. The laser will turn on within 1ms when TX_DISABLE is low (TTL logic “0”).

Receiver Section

The receiver utilizes a MSM detector integrated with a trans-impedance preamplifier in an OSA. This OSA is connected to a circuit providing post-amplification quantization, and optical signal detection.

Receive Loss (RX_LOS)

The RX_LOS is high (logic “1”) when there is no incoming light from the companion transceiver. This signal is normally used by the system for the diagnostic purpose. The signal is operated in TTL level.

GBIC-MMF

**1-P 1000Base-SX Mini-GBIC module (MM, LC)
550m/850nm, 1.25Gbps, 3.3/5v**

Typical BER Performance of Receiver versus Input Optical Power Level

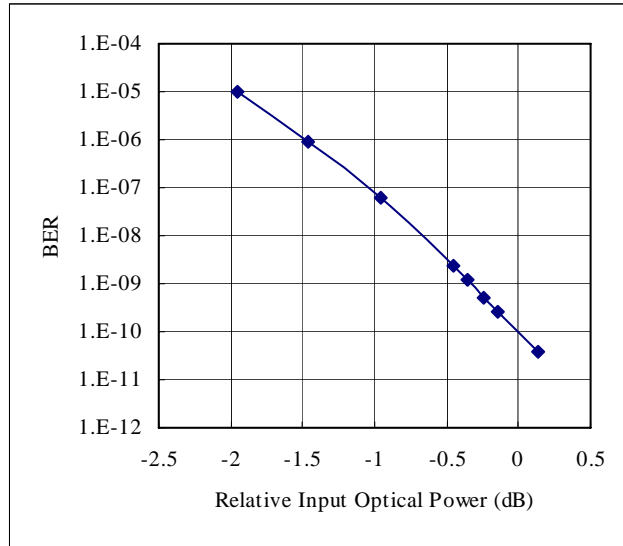

The figure shows the relationship between typical trade-off of BER and Relative Input Optical Power. Besides the required BER = 1×10^{-12} of the Gigabit Ethernet Physical Layer Standard, the transceiver can be operated at other Bit-Error-Rate conditions. The Relative Input Optical Power in dB is referenced to the actual sensitivity of the device. For BER conditions better than 1×10^{-12} , more input signal is needed (+dB).

Eye Diagram

Transmitter

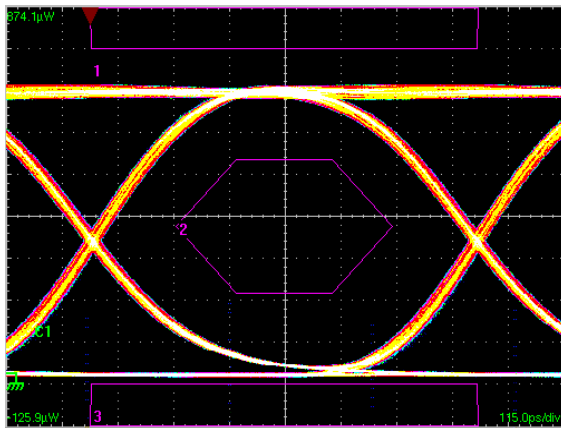

Signal pattern: PRBS 7

Receiver

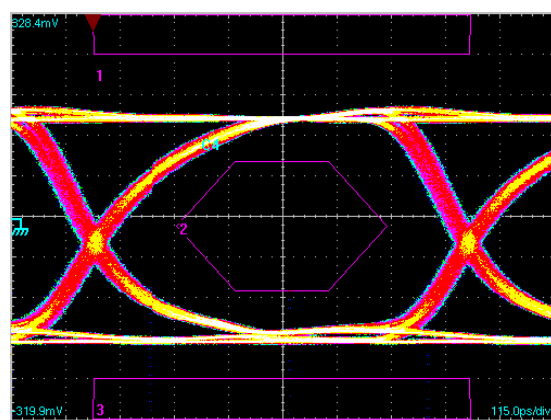

Signal pattern: PRBS 7
Input Power: -19 dBm

GBIC-MMF

**1-P 1000Base-SX Mini-GBIC module (MM, LC)
550m/850nm, 1.25Gbps, 3.3/5v**

Dimensions

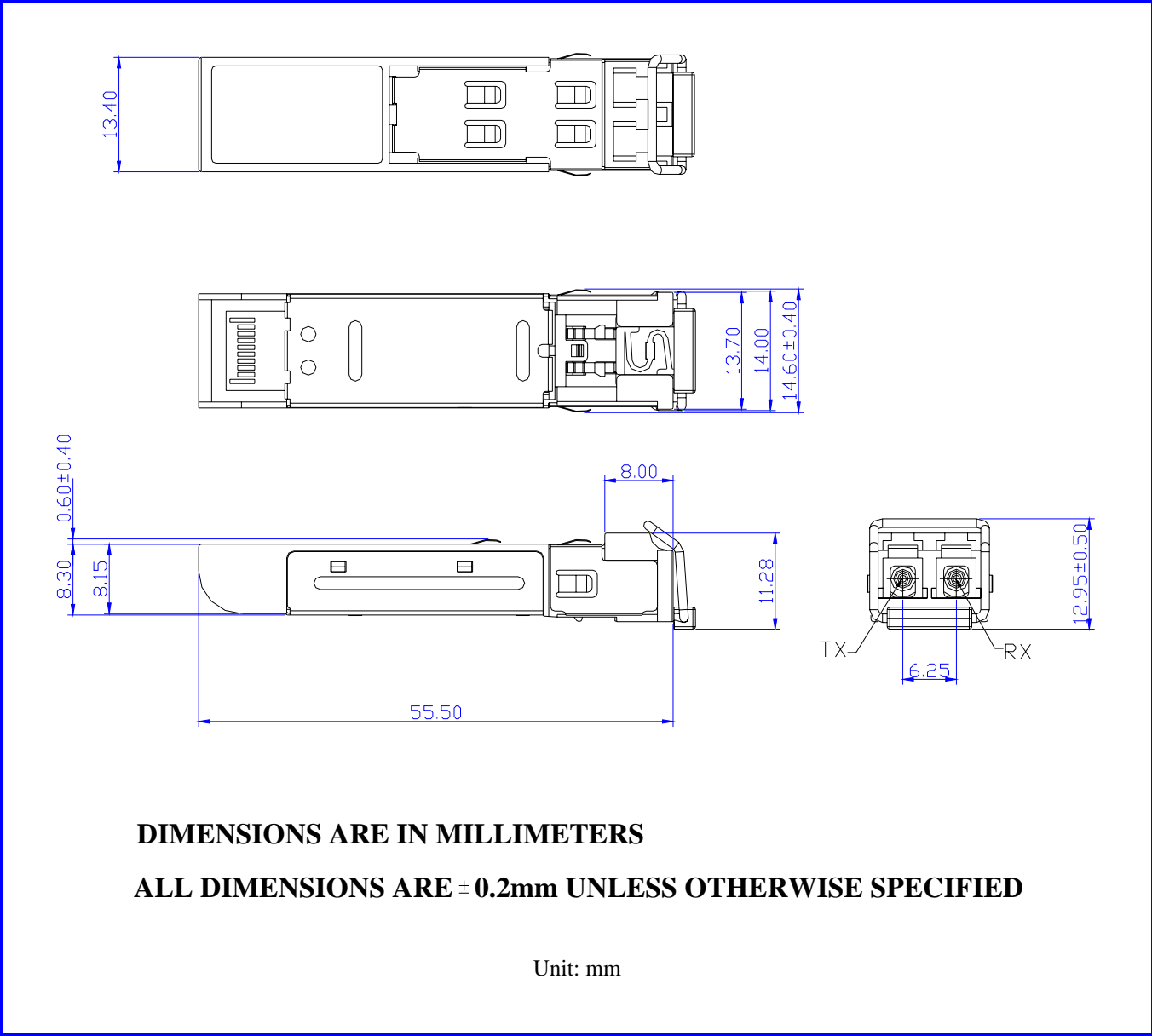

DIMENSIONS ARE IN MILLIMETERS

ALL DIMENSIONS ARE ± 0.2mm UNLESS OTHERWISE SPECIFIED

Unit: mm

GBIC-MMF

**1-P 1000Base-SX Mini-GBIC module (MM, LC)
550m/850nm, 1.25Gbps, 3.3/5v**

SFP host board mechanical layout

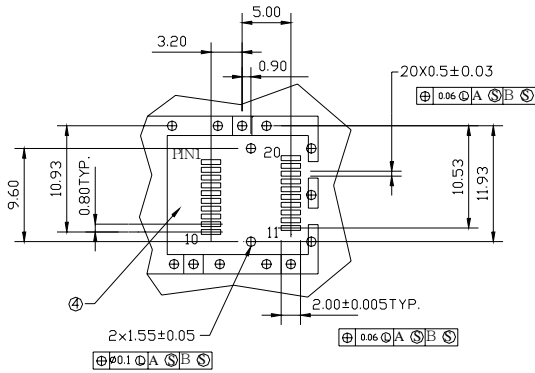
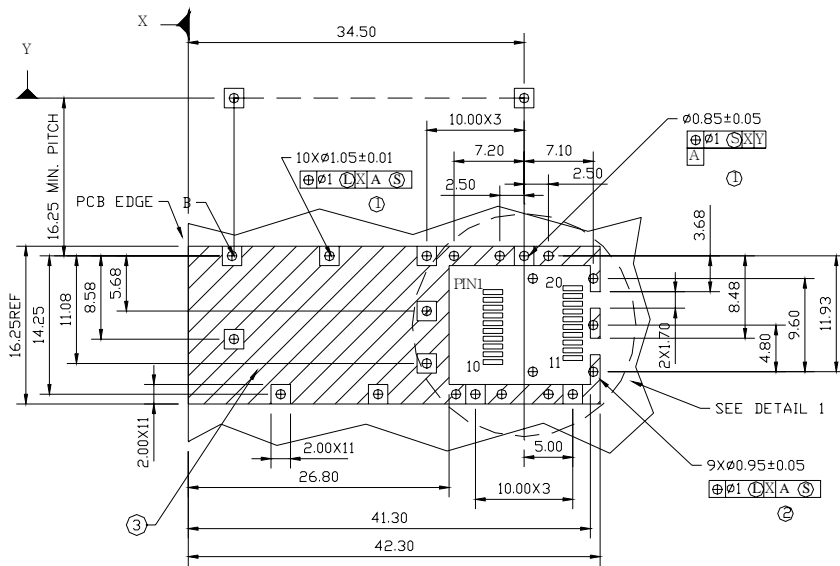

DETAIL 1

LEGEND

1. PADS AND VIAS ARE CHASSIS GROUND
2. THROUGH HOLES, PLATING OPTIONAL
3. HATCHED AREA DENOTES COMPONENT AND TRACE KEEPOUT (EXCEPT CHASSIS GROUND)
4. AREA DENOTES COMPONENT KEEPOUT (TRACES ALLOWED)

DIMENSIONS ARE IN MILLIMETERS

Unit: mm

GBIC-MMF

**1-P 1000Base-SX Mini-GBIC module (MM, LC)
550m/850nm, 1.25Gbps, 3.3/5v**

Assembly drawing

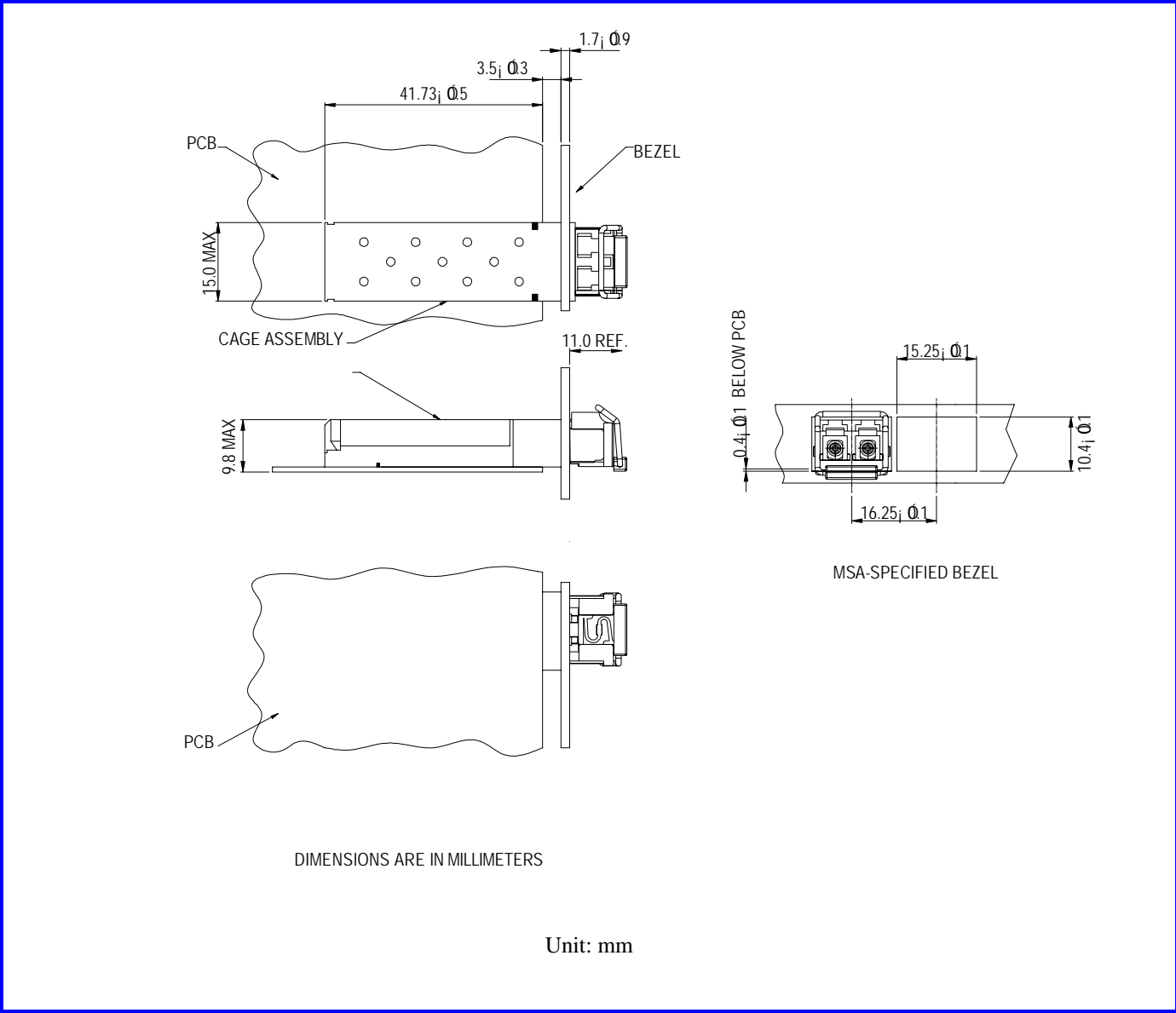

GBIC-MMF

1-P 1000Base-SX Mini-GBIC module (MM, LC) 550m/850nm, 1.25Gbps, 3.3/5v

Pin Assignment

Pin-Out

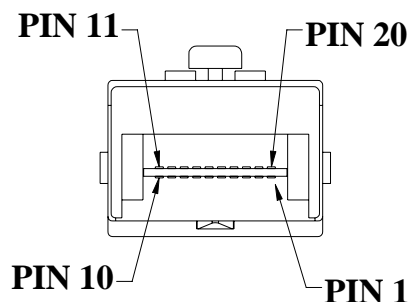

Pin	Signal Name	Description
1	T_{GND}	Transmit Ground
2	TX_FAULT	Transmit Fault
3	$TX_DISABLE$	Transmit Disable
4	$MOD_DEF (2)$	SDA Serial Data Signal
5	$MOD_DEF (1)$	SCL Serial Clock Signal
6	$MOD_DEF (0)$	TTL Low
7	$RATE_SELECT$	Open Circuit
8	RX_LOS	Receiver Loss of Signal, TTL High, open collector
9	R_{GND}	Receiver Ground
10	R_{GND}	Receiver Ground
11	R_{GND}	Receiver Ground
12	$RX-$	Receive Data Bar, Differential PECL, ac coupled
13	$RX+$	Receive Data, Differential PECL, ac coupled
14	R_{GND}	Receiver Ground
15	V_{CCR}	Receiver Power Supply
16	V_{CCT}	Transmitter Power Supply
17	T_{GND}	Transmitter Ground
18	$TX+$	Transmit Data, Differential PCEL, ac coupled
19	$TX-$	Transmit Data Bar, Differential PCEL, ac coupled
20	T_{GND}	Transmitter Ground

GBIC-MMF

**1-P 1000Base-SX Mini-GBIC module (MM, LC)
550m/850nm, 1.25Gbps, 3.3/5v**

Eye Safety Mark

The KM2 series multimode transceiver is a class 1 laser product. It complies with EN 60825-1 and FDA 21 CFR 1040.10 and 1040.11. In order to meet laser safety requirements the transceiver shall be operated within the Absolute Maximum Ratings.

Caution

All adjustments have been done at the factory before the shipment of the devices. No maintenance and user serviceable part is required. Tampering with and modifying the performance of the device will result in voided product warranty.

Required Mark

Class 1 Laser Product
Complies with
21 CFR 1040.10 and 1040.11

Note : All information contained in this document is subject to change without notice.

pakedgedevice&software, inc

GBIC-MMF

**1-P 1000Base-SX Mini-GBIC module (MM, LC)
550m/850nm, 1.25Gbps, 3.3/5v**

Technical Support

Please visit our website for up-to-date support information:

Website: **www.pakedge.com**

Email: **support@pakedge.com**

CONTACT INFORMATION:

Pakedge Device & Software Inc.

1011 Edwards Road

Burlingame, CA 94010

© Pakedge Device & Software Inc. 2009

All Rights Reserved